

KLIXON | TIME DELAY RELAYS

600 Series, Snap-Action Automatic or Manual Reset

The Klixon® 600 series thermal time delay is a snap-acting relay that performs in any position without contact chatter or noise. A wide variety of switch configurations are available including SPST, SPDT, and DPST automatic reset and SPST manual reset.

The switch and actuating elements incorporate the proven Klixon® snap-action bimetallic disc.

Sensata Technologies has been a leading global supplier of sensors & switches for over 50 years.

Key Features

- Silent Operation
- Voltage Compensating
- Snap-Action
- Small Size
- Low Cost
- Contact ratings - to 30 Amps at 240 Volts and 23 Amps at 277 Volts
- Automatic or Manual Reset
- Shock and Vibration Resistant
- Mounts in any Position
- DPST, SPST, or SPDT Switch Action

Description

The positive temperature coefficient (PTC) heater element provides voltage compensation over a wide range without the danger of over-heating at high voltage. This assures device actuation under low voltage conditions due to its unique feature of always stabilizing at a specified temperature regardless of ambient temperature or voltage. This will allow the use of a common device over a wide voltage range (example 208V to 277V). Available heater voltages range from 6 volts to 277 volts.

This switch and actuating element has proven to be highly reliable since its introduction in 1960. A variety of terminals and mounting plates are available to meet the installation requirements of most applications.

The 600 series is available in a variety of capacity ratings which are identified below: (A.R. = Automatic Reset, M.R. = Manual Reset).

Switch Rating

- 60000 - High Capacity - A.R.
- 60002 - Millivolt Capacity - A.R.
- *60004 - Extra High Capacity - A.R.
- 60006 - Pilot Duty Capacity - A.R.
- 60011 - High Capacity - M.R. Manual Override
- 60012 - Millivolt Capacity - M.R. Manual Override
- 60013 - Extra High Capacity - M.R. Trip Free
- 60015 - High Capacity - M.R. Manual Override

The switch action is identified by the following letter designations.

(N.O. = Normally Open;
N.C. = Normally Closed)

Switch Action

- A – SPST N.O.
- B – SPST N.C.
- C – SPDT contacts 1-3 N.O.
- D – SPDT contacts 1-3 N.C.
- E – DPST N.O.
- F – DPST N.C.
- J – DPST N.C., M.R.

* U.L. Recognition Pending

KLIXON | TIME DELAY RELAYS

600 Series, Snap-Action Automatic or Manual Reset

Electrical Clearances

The switch circuit of the 600 series is designed to provide electrical clearances of 3/8 inch through air to ground and 1/2 inch over surface to ground except on switch constructions E, F and J where clearances are 1/4 inch through air and 3/8 inch over surface to ground. The electrical clearances of the heater circuit vary depending upon the specific construction required in an application. The clearance to ground of the heater circuit is designed by one of the following numbers.

Designation Number	Through Air	Over Surface
0†	3/8 inch	1/2 inch
1	1/16 inch	1/16 inch
4	1/4 inch	3/8 inch

† Class II (30(volts or less)) heaters

Heater-Switch Connections

The 600 type can be supplied with one heater terminal common to either terminal #1 or #3 of the switch assembly. Standard construction is with separate heater terminals.

Mountings

Standard mounting plates shown below are available to meet most application requirements.

Terminals

Standard terminal types are listed below. Special switch terminals such as double quick connects, female quick connects, and .187" x .032" quick connects may be available for a specific switch terminal. Consult marketing for details.

Switch terminals:

solder type
screw type
.250" x .032" Q.C.

Heater Terminals

solder type
.187" x .020" Q.C.
.250" x .032" Q.C. (available at additional cost)

Use 12 gauge or larger wire for loads greater than 15 amperes.

Timings

The 600 series relay can be supplied in a wide variety of timings to meet specific application requirements. Timings are varied by the selection of the proper operating temperature of the bimetallic disc and the proper heater configuration for the specific application.

Examples of standard timing characteristics at 75°F are shown below.*

Voltage	Heat Time*	Cool Time**
24	1-60 sec.	1-45 sec.
	1-30	45-75
	30-75	1-40
	30-110	1-45
120/240	20-70 sec.	20-80 sec.
	30-110	15-65

*Cool time after 6 min. soak time

**Optional timings available at extra cost – please consult marketing

Ambient Rating

Ambient Exposure Range:
-40°F to 250°F

Ambient Operating Range:
-40°F to 152°F
(200°F Rating Available)

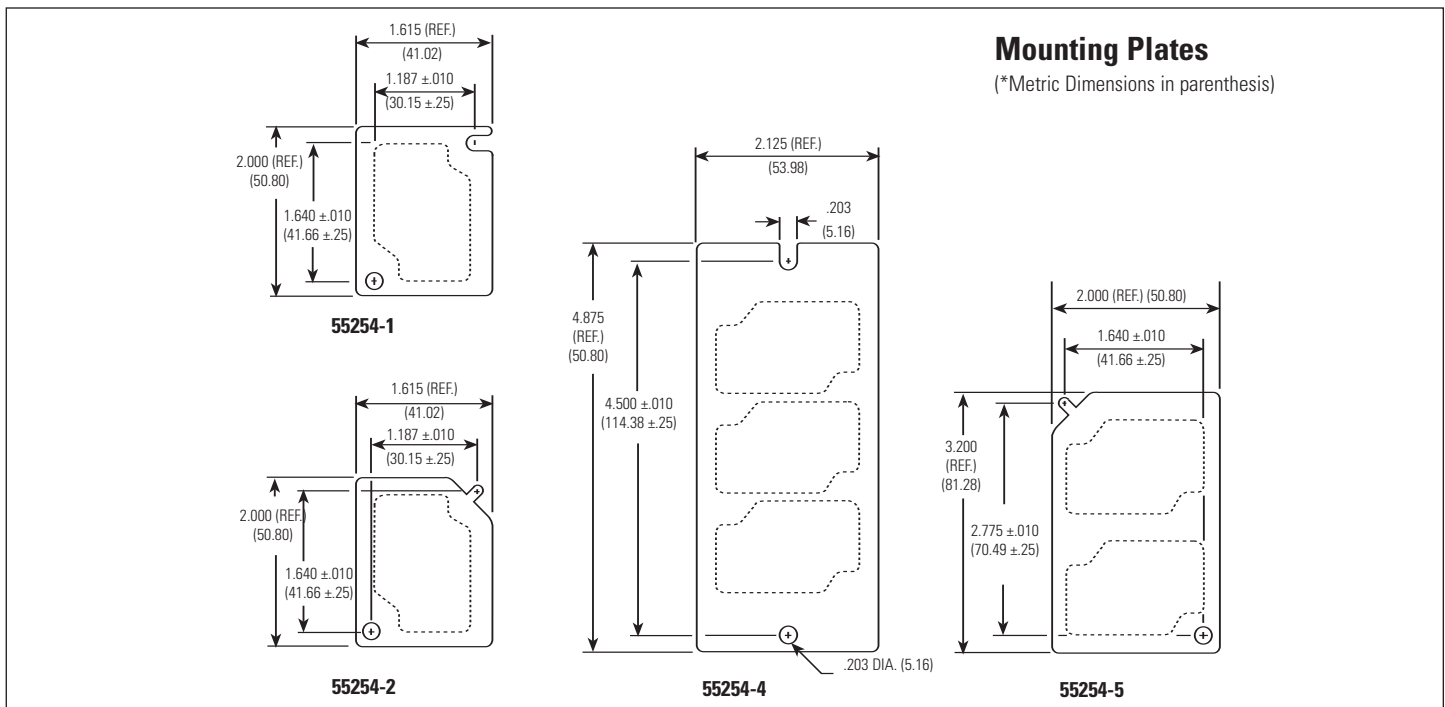

KLIXON® | TIME DELAY RELAYS

600 Series, Snap-Action Automatic or Manual Reset

Part Number System

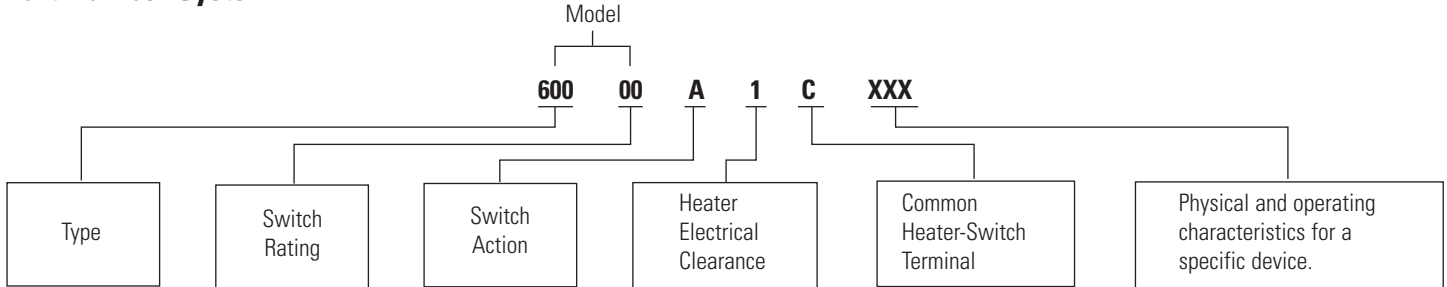

U.L. Electrical Ratings**

U.L. File E9977 CSA File 21794
 U.L. Guide XAPX2 CSA Guide 400-E-O; CSA Class 4813, 4823

Device			120 V				240 V				277 V				480 V				Millivolt DC
Model	Switch Action	Contacts	Res	FLA	LRA	Pilot Duty VA	Res	FLA	LRA	Pilot Duty VA	Res	FLA	LRA	Pilot Duty VA	Res	FLA	LRA	Pilot Duty VA	
*60000	A,B,C,D,	1-3	30	23	88	480	30	23	88	480	23	23	88	1630	12.5	5	10	400	
	C,D	1-2	10	5.8	34.8	125	5	4.2	17.4	270	5	-	-	125	3	3	5	125	
	E,F	1-3	30	23	88	480	30	23	88	480	23	23	88	1630	12.5	-	-	-	
	E,F	4-5	30	23	88	480	30	23	88	480	23	23	88	163	12.5	5	10	400	
	J	1-3 / 4-5	30	23	88	480	30	23	88	480									
60002	A,B	1-3				125													
60006	A,B,C,D	1-3				125													
	C,D	1-2				125													
60011	B	1-3	30	10	60	480	30	7	42	480				690	48			690	
60012	B	1-3																	800
60013	B	1-3	48	16	96	480	48	8	48	690	48								
60015	B	1-3	30	10	60	480	30	7	42	480	25			690					
60016	B	1-3				125													

*In addition to the ratings in the table, the 60000 A, B, E and F are U.L. rated for a combination load of 23 amps resistive at 240 VAC in series with a blower motor load up to 7 FLA / 42 LRA at 240 VAC. Consult marketing for additional ratings. The 60000 A, B, E, F are also U.L. rated for a combination load of 13 amps resistive and 5 amps inductive / 30 LRA at 480 VAC.

**Use 12 gauge or larger wire size for loads greater than 15 amperes.

How to Order Samples

When ordering samples, faster service can be rendered if the application is described in detail. Please specify the following:

- Type relay _____
- No. of samples _____
- Heat time: _____ sec. to _____ sec. @ _____ volts @ _____ °F
- Cool time: _____ sec. to _____ sec. after min. soak time @ _____ °F
- Heater voltage:
 - 12 208/240
 - 24 277
 - 120

- Ambient:
 - Operating: Min. _____ °F Max. _____ °F
 - Exposure: Min. _____ °F Max. _____ °F
- Switch Action:
 - A - SPST N.O.
 - B - SPST N.C.
 - C - SPDT contacts 1-3 N.O.
 - D - SPDT contacts 1-3 N.C.

- Heater Construction:
 - Separate terminals
 - Heater common to:
 - #1 or #3

- Heater terminals:
 - Solder
 - .187 x .020 Q.C.
 - .250 x .032 Q.C.

- Switch Terminal:
 - #1 type Angle
 - #2 type Angle
 - #3 type Angle
 - #4 type Angle

- Mounting Plate _____
- Circuit Diagram _____
- Electrical load: _____
- Equipment used on: _____
- Function of relay _____
- Annual volume _____

KLIXON® | TIME DELAY RELAYS

600 Series, Snap-Action Automatic or Manual Reset

Metric dimensions in parenthesis

Single Pole Single Throw

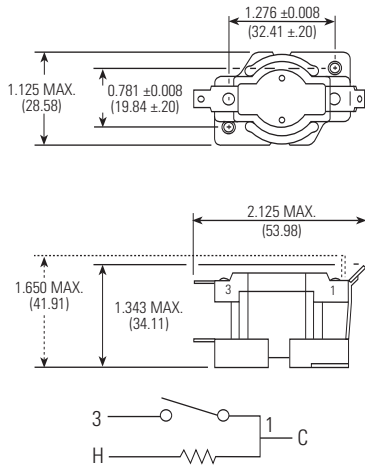

Single Pole Double Throw

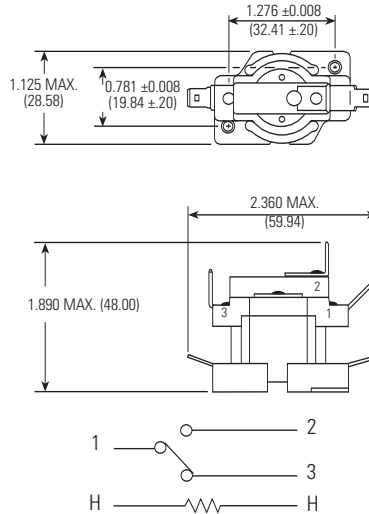

Double Pole Single Throw Manual reset – Manual Override

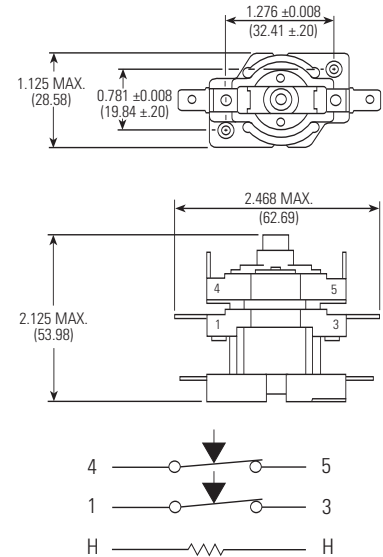

Double Pole Single Throw

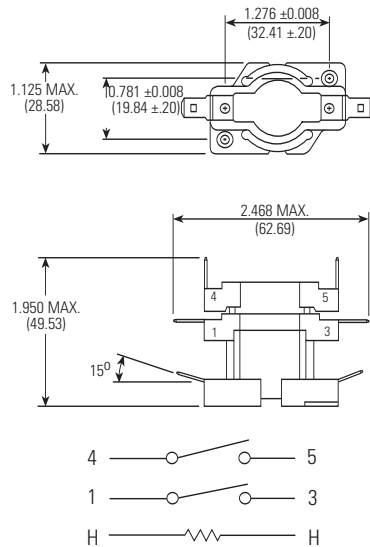

Single Pole Single Throw Manual Reset – Trip free

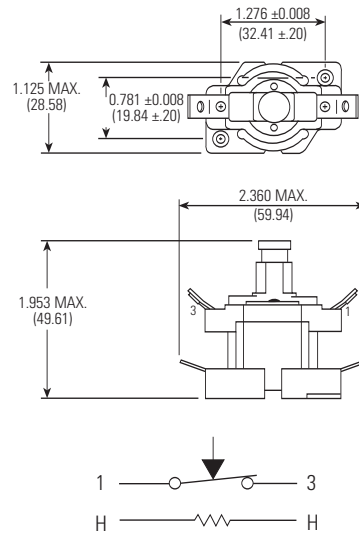

Applications

Sequencing of heater banks in:

- Electric furnaces
- Baseboard heaters
- Duct heaters
- Suspension heaters
- Recreational vehicle blower and element control.
- Heat pump blower and heating element control.
- Motor speed switching in air conditioning (high speed)/ heating systems (low speed) where a single set of contacts handle combination motor and heater element loading in the heater function.
- Control circuits requiring definite sequence of operation on both start up and shut down.



The World Depends on Sensors and Controls

Sensata Technologies

529 Pleasant Street, MS B19
 Attleboro, Massachusetts 02703-0964
 Phone: 1-888-438-2214
 1-508-236-1894
 1-508-236-3192
 Fax: (508) 236-2349
 email: sensata@sensata.com
www.sensata.com

Important Notice: Sensata Technologies (Sensata) reserves the right to make changes to or discontinue any product or service identified in this publication without notice. Sensata advises its customers to obtain the latest version of the relevant information to verify, before placing any orders, that the information being relied upon is current. Sensata assumes no responsibility for infringement of patents or rights of others based on Sensata applications assistance or product specifications since Sensata does not possess full access concerning the use or application of customers' products. Sensata also assumes no responsibility for customers' product designs.